

Section 02050

DEMOLITION AND SALVAGE

PART 1 - GENERAL

1-1. SCOPE. This section covers the demolition of existing piping and the salvage of existing materials and equipment as indicated on the drawings.

1-2. GENERAL. Contractor shall be responsible for all work under this section.

PART 2 - PRODUCTS

Not used.

PART 3 - EXECUTION

3-1. DEMOLITION.

3-1.01. Structure Demolition. Not used.

3-1.02. Piping and Equipment Demolition. The piping and equipment indicated to be removed shall be removed shall become the property of Contractor. All such items shall be promptly removed from the jobsite.

3-1.03. Sitework Demolition. Not used.

3-2. SALVAGE.

3-2.01. Items to be Salvaged by Owner. Not used.

3-2.02. Items to be Salvaged by Contractor. Removed and salvaged (reused) equipment or facilities shall include removal and salvage of all accessories, piping, wiring, supports, electrical equipment and devices, baseplates and frames, and all other appurtenances, unless otherwise directed, and as indicated on the drawings.

Contractor shall carefully remove, in a manner to prevent damage, all materials and equipment specified herein or indicated to be salvaged and to be reused. Contractor shall store and protect salvaged items specified or indicated to be reused in the work. Any items damaged in removal, storage, or handling through carelessness or improper procedures shall be replaced by Contractor in kind or with new items.

Contractor may, at his option, furnish and install new items instead of those specified or indicated to be salvaged and reused, in which case such removed items will become Contractor's property.

End of Section

(PUEBLO, COLORADO)
(DIORIO WRF)
(AMMONIA AND NUTRIENT REMOVAL)
(SECTION 4 – LIFT STATION RENOVATIONS) 02050
(165157.304)
(01/05/10) -2-

Section 02202

TRENCHING AND BACKFILLING

PART 1 - GENERAL

1-1. SCOPE. This section covers clearing, grubbing, and preparation of the site; removal and disposal of all debris; excavation and trenching; the handling, storage, transportation, and disposal of all excavated material; all necessary sheeting, shoring, and protection work; preparation of subgrades; pumping and dewatering as necessary; protection of adjacent property; backfilling; pipe embedment; surfacing and grading; and other appurtenant work.

1-2. GENERAL. With reference to the terms and conditions of the construction standards for excavations set forth in OSHA "Safety and Health Regulations for Construction", Chapter XVII of Title 29, CFR, Part 1926, Contractor shall employ a competent person and, when necessary based on the regulations, a registered professional engineer, to act upon all pertinent matters of the work of this section.

1-3. SUBMITTALS. Drawings, specifications, and data covering the proposed materials shall be submitted in accordance with the Submittals section.

1-3.01. Filter Fabric Data. Not used.

1-4. BASIS FOR PAYMENT.

1-4.01. Trench Sheeting. No additional payment above the Contract Price will be made for trench sheeting left in place.

1-5. INSURANCE. Not used.

PART 2 - PRODUCTS

2-1. MATERIALS.

2-1.01. Filter Fabric. The fabric shall be provided in rolls wrapped with covering for protection from mud, dirt, dust, and debris.

2-1.01.01. Filter Fabric Type A. Not used.

- 2-1.01.02. Filter Fabric Type B. Not used.
- 2-1.02. Polyethylene Film. Not used.
- 2-1.03. Tunnel Liner Plates. Not used.
- 2-1.04. Smooth Steel Pipe. Not used.
- 2-1.05. Wood Skids. Not used.
- 2-1.06. Casing Insulators. Not used.
- 2-1.07. Stabilized Sand Backfill. Not used.
- 2-1.08. End Closure. Not used.
- 2-1.09. Inundated Sand Fill. Not used.
- 2-1.10. Graded Gravel Fill. Not used.
- 2-1.11. Controlled Low Strength Material (CLSM) Fill. Not used.
- 2-1.12. Granular Fill. Granular fill material shall be crushed rock or gravel. Granular fill shall be free from dust, clay, and trash; hard, durable, non-friable; and shall be graded 3/4 inch to No. 4 as defined in ASTM C33 for No. 67 coarse aggregate. Granular fill shall meet the quality requirements for ASTM C33 coarse aggregate.
- 2-2. MATERIALS TESTING. Not used.

PART 3 - EXECUTION

3-1. CLEARING. All clearing shall be performed as necessary for access, stringing of pipeline materials, and construction of the pipeline and appurtenant structures.

3-2. EXCAVATION. Excavations shall provide adequate working space and clearances for the work to be performed therein and for installation and removal of concrete forms. In no case shall excavation faces be undercut for extended footings.

Subgrade surfaces shall be clean and free of loose material of any kind when concrete is placed thereon.

Except where exterior surfaces are specified to be damp-proofed, monolithic concrete manholes and other concrete structures or parts thereof, which do not have footings that extend beyond the outside face of exterior walls, may be placed directly against excavation faces without the use of outer forms, provided that such faces are stable and also provided that a layer of polyethylene film is placed between the earth and the concrete.

Excavations for manholes and similar structures constructed of masonry units shall have such horizontal dimensions that not less than 6 inches clearance is provided for outside plastering.

3-2.01. Classification of Excavated Materials. Not used.

3-2.02. Preservation of Trees. Not used.

3-2.03. Blasting. Blasting or other use of explosives for excavation will not be permitted.

3-2.04. Dewatering. Dewatering equipment shall be provided to remove and dispose of all surface water and groundwater entering excavations, trenches, or other parts of the work. Each excavation shall be kept dry during subgrade preparation and continually thereafter until the structure to be built, or the pipe to be installed therein, is completed to the extent that no damage from hydrostatic pressure, flotation, or other cause will result.

All excavations trenches which extend down to or below groundwater shall be dewatered by lowering and keeping the groundwater level to the minimum depth of 12 inches, beneath such excavations. The specified dewatering depth shall be maintained below the prevailing bottom of excavation at all times.

Surface water shall be diverted or otherwise prevented from entering excavations or trenches to the greatest extent possible without causing damage to adjacent property.

Contractor shall be responsible for the condition of any pipe or conduit which he may use for drainage purposes, and all such pipe or conduit shall be left clean and free of sediment.

Contractor shall obtain from the appropriate agencies and authorities, the dewatering and stormwater discharge permits required to remove and dispose of groundwater, surface water, and any other water used in Contractor's operations. The permits shall be obtained prior to start of construction.

3-2.05. Sheeting and Shoring. Except where banks are cut back on a stable slope, excavations for structures and trenches shall be supported with steel sheet piling and shoring as necessary to prevent caving or sliding.

Sheet piling or other excavation support systems shall be installed as necessary to limit the extent of excavations for deeper structures and to protect adjacent structures and facilities from damage due to excavation and subsequent construction. Contractor shall assume complete responsibility for, and shall install adequate protection systems for prevention of damage to existing facilities.

Sheeting, shoring and excavation support systems shall be designed by a professional engineer registered in the state where the project is located.

Trench sheeting may be removed if the pipe strength is sufficient to carry trench loads based on trench width to the back of sheeting. Trench sheeting shall not be pulled after backfilling. Where trench sheeting is left in place, it shall not be braced against the pipe, but shall be supported in a manner which will preclude concentrated loads or horizontal thrusts on the pipe. Cross braces installed above the pipe to support sheeting may be removed after pipe embedment has been completed. Trench sheeting shall be removed unless otherwise permitted by Engineer. Trench sheeting will not be removed, if in the opinion of Engineer, removal of the sheeting will cause damage to the facility it is protecting. If left in place, the sheeting shall cut off 12 inches below finished grade. The design of the support system shall be such as to permit complete removal while maintaining safety and stability at all times.

3-2.06. Stabilization. Sub-grades for trench bottoms shall be firm, dense, and thoroughly compacted and consolidated; shall be free from mud and muck; and shall be sufficiently stable to remain firm and intact under the feet of the workers.

Sub-grades for concrete structures or trench bottoms which are otherwise solid, but which become mucky on top due to construction operations, shall be reinforced with crushed rock or gravel as specified for granular fills. The stabilizing material shall be placed in a manner that no voids remain in the

granular fill. All excess granular fill with unfilled void space shall be removed. The finished elevation of stabilized sub-grades shall not be above sub-grade elevations indicated on the drawings.

3-3. TRENCH EXCAVATION.

3-3.01. Alignment, Grade, and Minimum Cover. Not used.

3-3.02. Maximum Trench Widths. Not used.

3-3.03. Minimum Trench Widths. Not used.

3-3.04. Mechanical Excavation. The use of mechanical equipment will not be permitted in locations where its operation would cause damage to trees, buildings, culverts, or other existing property, utilities, or structures above or below ground. In all such locations, hand excavating methods shall be used.

Mechanical equipment used for trench excavation shall be of a type, design, and construction, and shall be so operated, that the rough trench excavation bottom elevation can be controlled, and that trench alignment is such that pipe, when accurately laid to specified alignment, will be centered in the trench with adequate sidewall clearance. Undercutting the trench sidewall to obtain sidewall clearance will not be permitted.

In locations where maximum trench widths are required for designated rigid conduits, mechanical equipment shall be operated so that uniform trench widths and vertical sidewalls are obtained at least from an elevation 12 inches above the top of the installed pipe to the bottom of the trench.

3-3.05. Cutting Concrete Surface Construction. Not used.

3-3.06. Excavation Below Pipe Sub-grade. Not used.

3-3.07. Artificial Foundations in Trenches. Not used.

3-4. PIPE EMBEDMENT. Embedment materials both below and above the bottom of the pipe, classes of embedment to be used, and placement and compaction of embedment materials shall conform to the requirements indicated on Figure 1-02202 and to the following supplementary requirements.

Embedment material shall contain no cinders, clay lumps, or other material which may cause pipe corrosion.

3-4.01. Embedment Classes.

- a. Class A Arch Encasement. Not used.
- b. Class B Bedding. Class B bedding shall be used for all pipelines, and for all other pipelines.
- c. Class B Special Bedding. Not used.
- d. Class C Bedding. Not used.

3-4.02. Embedment for Ductile Iron and PVC Pipelines. Granular embedment for ductile iron and PVC pipelines shall be pea gravel or crushed rock with rounded or subrounded particles; crushed rock with sharp edges which could cause significant scratching or abrasion of the pipe or damage to the polyethylene tube protection shall not be used. Inundated sand may be used for granular embedment in locations where the use of water will cause no damage to adjacent property and where it can be placed and properly compacted without damage to the pipe.

3-4.03. Placement and Compaction. Granular embedment material shall be spread and the surface graded to provide a uniform and continuous support beneath the pipe at all points between bell holes or pipe joints. It will be permissible to slightly disturb the finished subgrade surface by withdrawal of pipe slings or other lifting tackle.

After each pipe has been graded, aligned, and placed in final position on the bedding material, and shoved home, sufficient pipe embedment material shall be deposited and compacted under and around each side of the pipe and back of the bell or end thereof by shovel slicing or other suitable methods to hold the pipe in proper position and alignment during subsequent pipe jointing and embedment operations.

Embedment material shall be deposited and compacted uniformly and simultaneously on each side of the pipe to prevent lateral displacement.

Each lift of granular embedment material shall be vibrated with a mechanical probe type vibrator or shovel sliced during placement to ensure that all spaces beneath the pipe are filled. Granular embedment shall be placed in maximum lift thickness of 6 inches and compacted. Each lift of embedment material shall be compacted with three passes (round trip) of a platform type vibrating compactor.

3-4.04. Groundwater Barrier. Not used.

3-5. TRENCH BACKFILL. All trench backfill above pipe embedment shall conform to the following requirements.

A layer of backfill material not more than 8 inches deep may be placed over concrete arch encasement or concrete reaction blocking after the concrete has reached its initial set, to aid curing. No additional backfill shall be placed over arch encasement or blocking until the concrete has been in place for at least 3 days.

3-5.01. Compacted Backfill. Compacted backfill will be required for the full depth of the trench above the embedment in all locations.

3-5.01.01. Job Excavated Material. Job excavated material may be used for compacted backfill when the job excavated material is finely divided and free from debris, organic material, cinders, any corrosive material, and stones larger than 3 inches in greatest dimension. Masses of moist, stiff clay shall not be used. Job excavated materials shall be placed in uniform layers not exceeding 8 inches in uncompacted thickness. Each layer of material shall have the best possible moisture content for satisfactory compaction. The material in each layer shall be wetted or dried as needed and thoroughly mixed to ensure uniform moisture content and adequate compaction. Increased layer thickness may be permitted for noncohesive material if Contractor demonstrates to the satisfaction of Engineer that the specified compacted density will be obtained. The method of compaction and the equipment used shall be appropriate for the material to be compacted and shall not transmit damaging shocks to the pipe. Job excavated material shall be compacted to 95 percent of maximum density at a moisture content within 2 percent of the optimum moisture content, as determined by ASTM D698 when that test is appropriate, or to 70 percent relative density as determined by ASTM D4253 and D4254 when those tests are appropriate.

3-5.01.02. Inundated Sand. Not used.

3-5.01.03. Graded Gravel. Gravel backfill shall be deposited in uniform layers not exceeding 12 inches in uncompacted thickness. The backfill shall be compacted with a suitable vibratory roller or platform vibrator to at least 70 percent relative density as determined by ASTM D4253 and D4254.

Groundwater barriers specified under pipe embedment shall extend to the top of the graded gravel backfill.

3-5.02. Ordinary Backfill. Not used.

3-5.03. Water-Settled Earth Backfill. Not used.

3-5.04. Structure Backfill. Not used.

3-5.05. Controlled Low Strength Material (CLSM). Not used.

3-6. TUNNEL EXCAVATION. Not used.

3-7. DRAINAGE MAINTENANCE. Not used.

3-8. PROTECTION OF TRENCH BACKFILL IN DRAINAGE COURSES. Not used.

3-9. FINAL GRADING AND PLACEMENT OF TOPSOIL. Not used.

3-10. DISPOSAL OF EXCESS EXCAVATED MATERIALS. Excess material from trench excavation sites shall be disposed of away from the site.

Broken concrete and other debris resulting from pavement or sidewalk removal, excavated rock in excess of the amount permitted to be installed in trench backfill, debris encountered in excavation work, and other similar waste materials shall be disposed of away from the site.

3-11. RESODDING. Not used.

3-12. SETTLEMENT. Not used.

End of Section

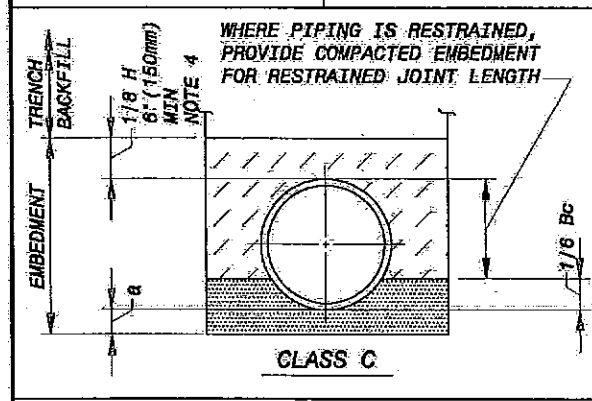
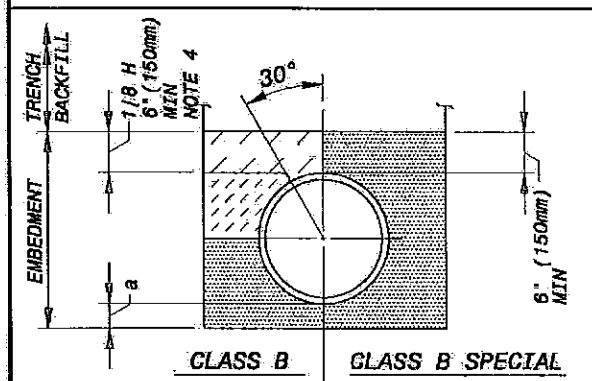
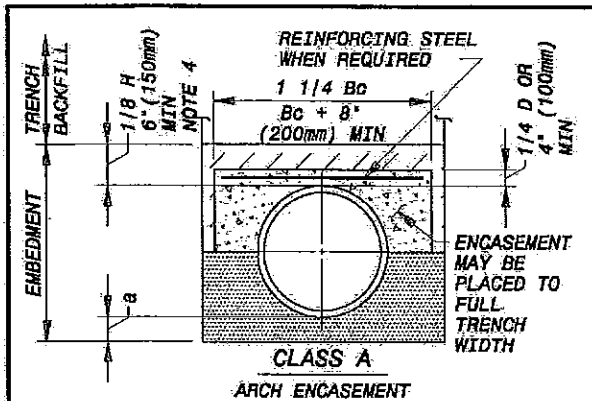

TABLE OF EMBEDMENT DEPTHS BELOW PIPE

D	a		a	
	MIN SOIL	MIN ROCK	MIN SOIL	MIN ROCK
	in	mm	in	mm
27" (875 mm) & SMALLER	3	75	6	150
30" (750 mm) TO 60" (1500 mm)	4	100	9	225
66" (1850 mm) & LARGER	6	150	12	300

- NOTES:**
1. GRANULAR EMBEDMENT MATERIAL SHALL BE CRUSHED ROCK OR PEA GRAVEL COARSE AGGREGATE SIZE NUMBER 7 (13 TO 4.75) ASTM C33. EMBEDMENT MATERIAL SHALL BE PLACED IN LAYERS NOT MORE THAN 6" (150mm) DEEP AND COMPACTED AS SPECIFIED.
 2. HAND PLACED EMBEDMENT SHALL BE FINELY DIVIDED MATERIAL FREE FROM DEBRIS AND STONES.
 3. COMPACTED EMBEDMENT SHALL BE FINELY DIVIDED JOB EXCAVATED MATERIAL FREE FROM DEBRIS, ORGANIC MATERIAL, AND STONES, PLACED IN UNIFORM LAYERS NOT MORE THAN 8" THICK, AND COMPACTED TO 96% MAXIMUM DENSITY AS DETERMINED BY ASTM D698; INUNDATED SAND; OR GRADED GRAVEL. GRANULAR EMBEDMENT MAY BE SUBSTITUTED FOR ALL OR PART OF THE COMPACTED EMBEDMENT.
 4. EMBEDMENT ABOVE THE TOP OF THE PIPE SHALL BE AN UNCOMPACTED LAYER FOR ALL INSTALLATIONS.
 5. REFER TO SPECIFICATIONS FOR GEOTECHNICAL FABRIC OR SPECIAL EMBEDMENT REQUIREMENTS FOR TRENCHES IN FINE SOILS EXTENDING BELOW GROUNDWATER LEVEL.
 6. TRENCH OUTLINES DO NOT INDICATE ACTUAL TRENCH EXCAVATION SHAPE, SOIL CONDITIONS, OR PRESENCE OF SHEETING LEFT IN PLACE. EMBEDMENT MATERIAL SHALL EXTEND THE FULL WIDTH OF THE ACTUAL TRENCH EXCAVATION.
 7. FOR RESTRAINED JOINT PIPE LENGTH WITH CLASS C EMBEDMENT THE BACKFILL ABOVE THE GRANULAR EMBEDMENT AND BELOW THE TOP OF THE PIPE SHALL BE COMPACTED EMBEDMENT.

LEGEND

- B_c OUTSIDE DIAMETER OF PIPE
- H COVER ABOVE TOP OF PIPE
- D NOMINAL PIPE SIZE
- a EMBEDMENT BELOW PIPE (SEE TABLE)

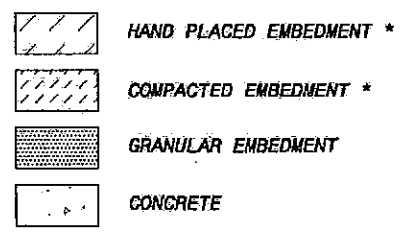

* OR GRANULAR EMBEDMENT

EMBEDMENTS FOR CONDUITS

BLACK & VEATCH

FIG 1-02202

Section 02704

PIPELINE PRESSURE AND LEAKAGE TESTING

PART 1 - GENERAL

1-1. SCOPE. This section covers field hydrostatic pressure and leakage testing of piping. The term "piping" shall be used in this section to refer to piping systems, pipelines, or sections thereof.

1-2. GENERAL. Engineer or Engineer's representative shall be present during testing and shall be notified of the time and place of testing at least 3 days prior to commencement of the work. All work shall be performed to the satisfaction of Engineer.

1-2.01. Testing Schedule and Procedure. A testing schedule and test procedure shall be submitted to Engineer for review and acceptance not less than 21 days prior to commencement of testing. The schedule shall indicate the proposed time and sequence of testing of the piping. The testing procedure shall establish the limits of the piping to be tested, the positions of all valves during testing, the locations of temporary bulkheads, and all procedures to be followed in performing the testing.

1-2.02. Special Testing Requirements. Not used.

1-2.03. Water. Water for testing shall be furnished as stipulated in the Temporary Facilities section. Following completion of testing, the water shall be disposed of in a manner acceptable to Engineer. Unless otherwise permitted, the water shall be kept out of the remainder of the piping.

PART 2 - PRODUCTS

2-1. TEST EQUIPMENT. All necessary connections between the piping to be tested and the water source, together with pumping equipment, water meter, pressure gauges, and all other equipment, materials, and facilities required to perform the specified tests, shall be provided. All required flanges, valves, bulkheads, bracing, blocking, and other sectionalizing devices shall also be

provided. All temporary sectionalizing devices shall be removed upon completion of testing. Vents shall be provided in test bulkheads where necessary to expel air from the piping to be tested.

Test pressures shall be applied by means of a force pump sized to produce and maintain the required pressure without interruption during the test.

Water meters and pressure gauges shall be accurately calibrated and shall be subject to review and acceptance by Engineer.

PART 3 - EXECUTION

3-1. FILLING AND VENTING. Before filling the piping with water, care shall be taken to ensure that all venting devices are properly installed and in the open position. Hand-operated vent valves shall not be closed until an uninterrupted stream of water is flowing from each valve. The rate of filling the piping with water must not exceed the venting capacity of the installed air vent valves and devices.

3-2. BLOCKING AND BACKFILLING. Piping shall be adequately blocked, anchored, and supported before the test pressure is applied.

3-3. PRESSURE TESTING. After the piping to be tested has been filled with water, the test pressure shall be applied and maintained without interruption within plus or minus 5 psi of test pressure for 2 hours plus any additional time required for Engineer to examine all piping being tested and for Contractor to locate any defective joints and pipe materials. The test pressure shall be in accordance with the requirements specified for pipeline or plant piping.

3-3.01. Pipeline Test Pressure. Piping shall be subjected to a hydrostatic test pressure of 100 psi.

3-3.02. Plant Piping Test Pressure. Not used.

3-4. PLANT PIPING LEAKAGE. Not used.

3-5. PIPELINE LEAKAGE TESTING. Following completion of pressure testing and acceptance by Engineer, the pipeline piping shall be subjected to a leakage test. The duration of the leakage test shall be 2 hours plus the additional time required for Engineer to make an accurate determination of leakage.

3-5.01. Leakage Test Pressure. The hydrostatic pressure maintained during the leakage test shall be at least 75 percent, but not more than 100 percent, of the pressure specified for pressure testing of the piping and shall be maintained within plus or minus 5 psi during the entire time that leakage measurements are being performed.

3-5.02. Leakage Measurement. Measurement of leakage shall not be attempted until all trapped air has been vented and a constant test pressure has been established. After the pressure has stabilized, piping leakage shall be measured with a suitable water meter installed in the pressure piping on the discharge side of the force pump.

3-5.03. Allowable Leakage. The term "leakage", as used herein, refers to the total amount of water which must be introduced into the piping during the leakage test to maintain the test pressure.

No piping will be accepted if and while it exhibits a leakage rate in excess of 0.1 gallon per hour.

All joints in piping shall be watertight and free from visible leaks during the leakage test. Each leak which is discovered within the correction period stipulated in the General Conditions shall be repaired by and at the expense of Contractor regardless of the amount that the total leakage may have been below the specified allowable leakage rate during the leakage test.

If the leakage test indicates a higher than allowable leakage rate, Contractor shall locate and repair leaking joints and other defective work to the extent necessary to reduce the leakage to an acceptable value.

End of Section

Section 02901

LANDSCAPING

PART 1 - GENERAL

1-1. SCOPE. This section covers the requirements and furnishing of all labor, materials, and equipment in providing landscaping at the project site. The following is a list of the Work included under this section:

- Furnishing and installation of landscaping rock.

1-2. GENERAL. All landscaping work shall be performed by a landscape subcontractor having demonstrated experience in the installation of plants on projects of similar size, and who employs only experienced personnel familiar with the required Work, and who shall provide adequate supervision by a qualified supervisor at all times when the Work is in progress.

1-3. SUBMITTALS.

1-3.01. Landscaping Rock. A 1/4 cubic foot sample of rock matching the color and texture of the existing landscaping rock shall be submitted to the Engineer for selection by the Owner. Once accepted, the selected material will be retained as a representative sample for future materials. Material not meeting the standards of the accepted sample shall be removed and replaced.

PART 2 - PRODUCTS

2-1. MATERIALS.

2-1.01. Landscaping Rock. Crushed rock for landscaping shall be hard, durable, washed free of foreign substances, and having a size comparable to the existing rock.

2-1.02. Weed-block Fabric. Acceptable products for use as a weed-block fabric shall be Dupont "Typar" or Mirafi "140". Equivalent products will be subject to Engineer's approval and must be permanent when in contact with ground, nonwoven, and permit free movement of water.

PART 3 - EXECUTION

3-1. INSTALLATION. The Work shall not be started until all surface grading and compaction has been completed. All ground surfaces previously covered by rock and that have been disturbed during construction shall be covered by rock. Landscaping gravel treatments shall be smooth and uniform and be free of surface irregularities, grass, brush, weeds, and debris.

3-1.01. Landscaping Rock. All landscaping rock shall be installed over weed-block fabric. Rock shall be installed in the areas and limits indicated on the drawings. The depth shall be 4 inches minimum unless otherwise indicated.

3-1.02. Cleanup. After completion of the construction operations, the entire site shall be cleared of excess soil and waste material, including but not limited to, stones, stumps, roots, brush, wire, grade stakes, and all objects that might be a hindrance to maintenance operations and affect the visual appearance of the site. All roads over which hauling operations have been conducted, despite the type of surfacing, shall be kept clean, and soil clods and debris left on the surface shall be removed. The wheels of vehicles shall be cleaned to avoid leaving soil upon the surface of roads, walks, and other paved areas.

End of Section

(PUEBLO, COLORADO)
(DIORIO WRF)
(AMMONIA AND NUTRIENT REMOVAL)
(SECTION 4 - LIFT STATION RENOVATIONS) 02901
(165157.304) -2-
(12/14/09)